

SECTION H-H

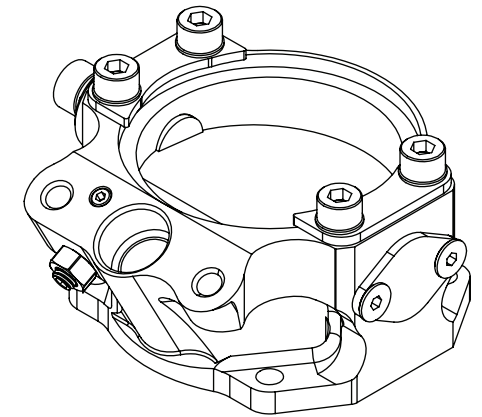
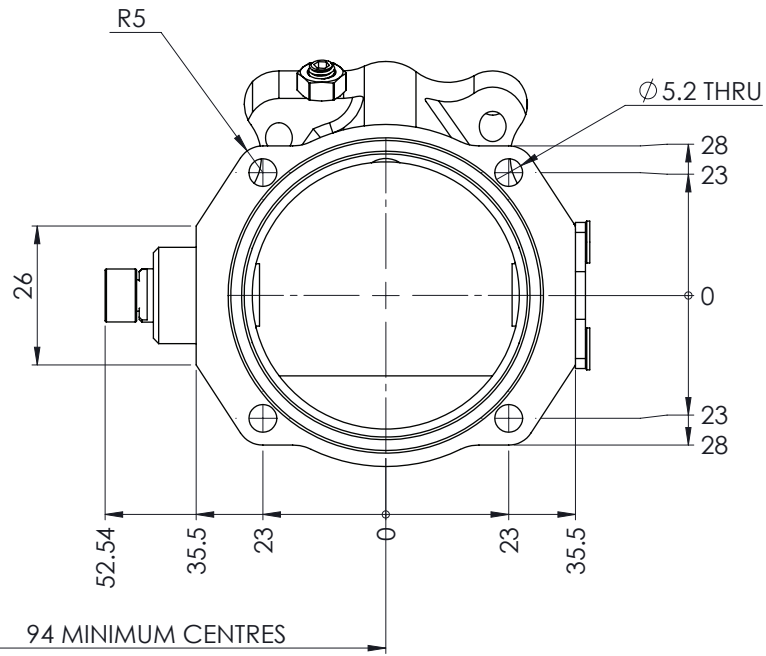

COPYRIGHT (c) 2013  
AT POWER LTD  
UNIT 9, CHESTNUT DRIVE, WYMONDHAM,  
NORFOLK, UK, NR18 9SB

UNLESS OTHERWISE STATED:  
DIMENSIONS IN MILLIMETRES  
TOLERANCES: LINEAR  $\pm 0.1$  ANGULAR  $\pm 0.5^\circ$   
SURFACE FINISH  $\sqrt{\text{ }}$  =  $\sqrt{\text{ }}$   
DRAWING STANDARDS TO ATQS 6003  
DATE FORMAT: DD/MM/YY

THIS DESIGN IS THE PROPERTY OF  
AT POWER THROTTLES LTD AND  
MUST NOT BE REPRODUCED OR  
COMMUNICATED WITHOUT  
AUTHORITY

CAD PLOT  
DO NOT  
SCALE

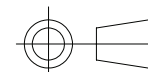

THIRD ANGLE PROJECTION

SCALE 1:1 WEIGHT 0.2 kg

DRAWN- S.HOW

DATE - 29/11/19

CHECKED - S.HOW

APPROVED - A.CLIFTON

MATERIAL

SEE COMPONENT PARTS

FINISH

SEE COMPONENT PARTS

DRAWING TITLE

ASSY - HOUSING - SINGLE -  
ROUND - 50MM - INJECTED

DRAWING NUMBER

102-105-00026

SHEET 2 OF 2 A3