

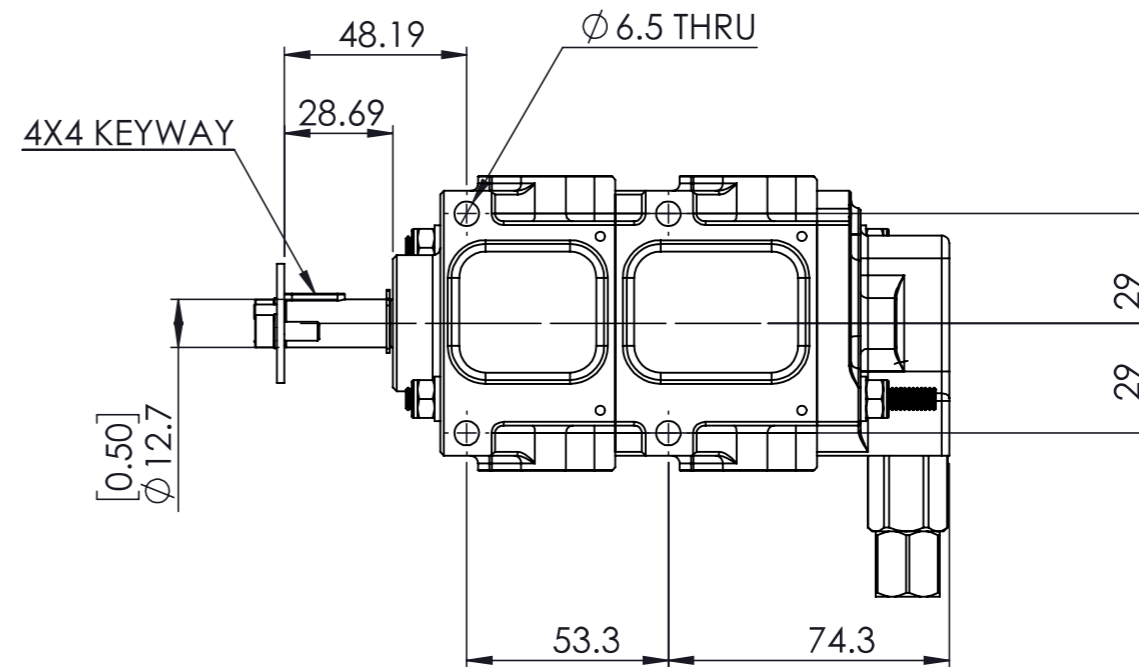

NOTES:

1. DISPLACEMENT PER REVERLUTION PER STAGE = 11.9 CC/REV
2. DISPLACEMENT AT 1000 RPM = 11.9 LT/MIN
3. PRV CRACKING PRESSURE:-
 MINIMUM = 2.9 BAR (42 PSI)
 MAXIMUM = 8.27 BAR (120PSI)
4. FOR EACH FULL TURN OF THE ADJUSTER THE CRACKING PRESSURE WILL INCREASE/DECREASE BY 0.25 BAR (3.6 PSI)

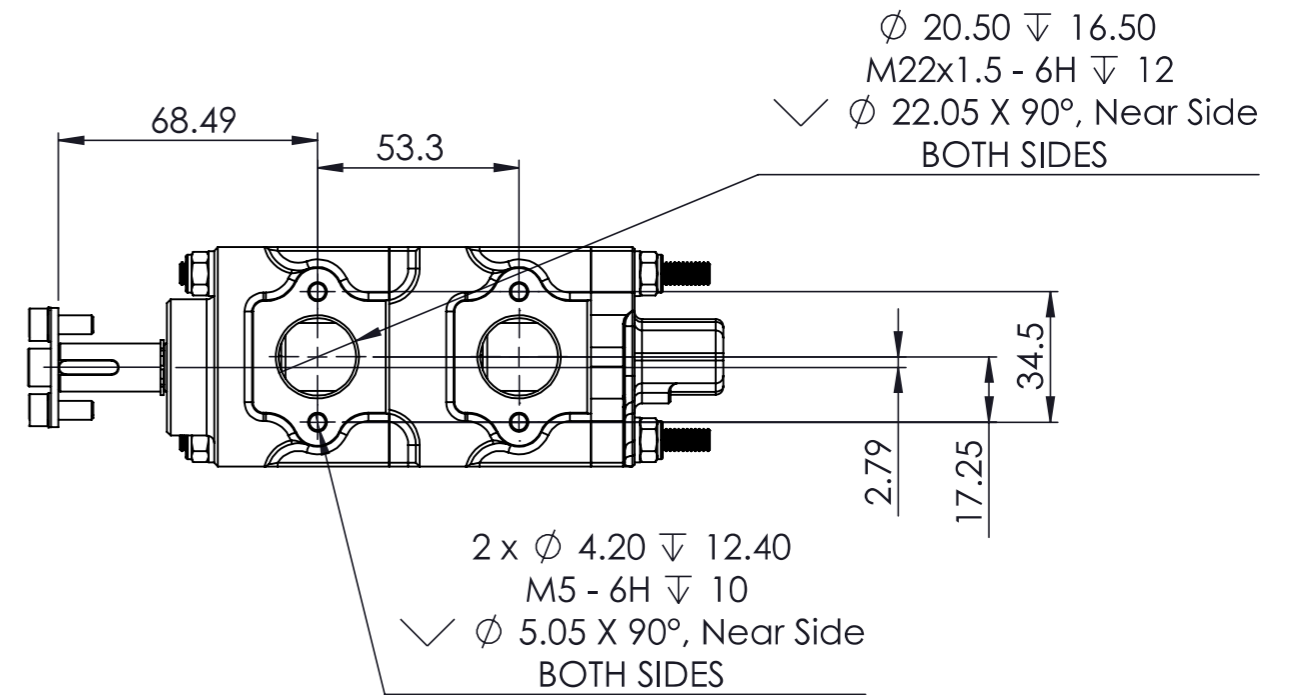
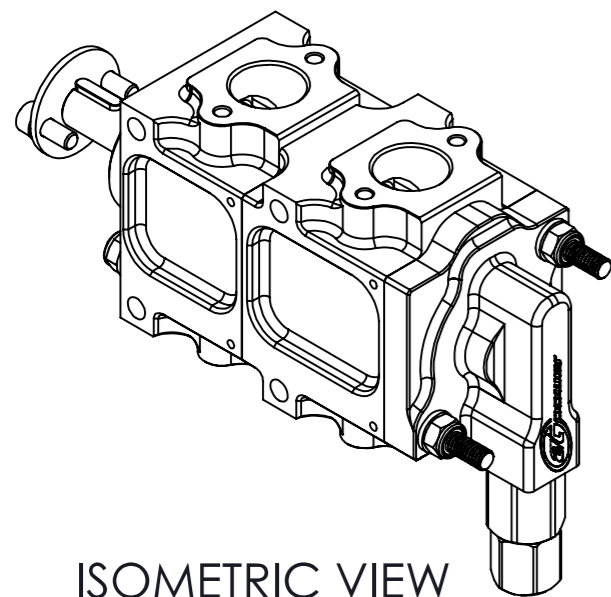
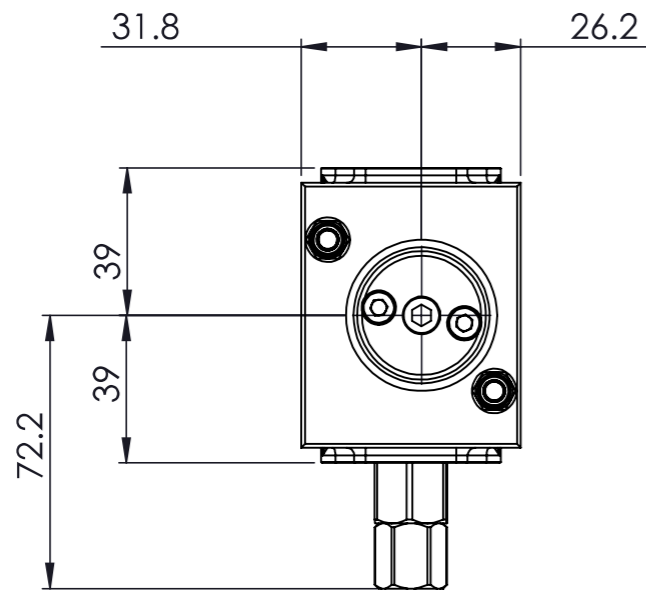
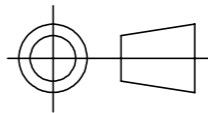

 COPYRIGHT (c) 2013 AT POWER LTD UNIT 9, CHESTNUT DRIVE, WYMONDHAM, NORFOLK, UK, NR18 9SB	 THIRD ANGLE PROJECTION	MATERIAL	SEE COMPONENT PARTS	
		FINISH	SEE COMPONENT PARTS	
UNLESS OTHERWISE STATED: DIMENSIONS IN MILLIMETRES TOLERANCES: LINEAR ± 0.1 ANGULAR ± 0.5° SURFACE FINISH ∇ = ∇ DRAWING STANDARDS TO ATQS 6003 DATE FORMAT: DD/MM/YY THIS DESIGN IS THE PROPERTY OF ACTIVE TECHNOLOGIES LTD AND MUST NOT BE REPRODUCED OR COMMUNICATED WITHOUT AUTHORITY	SCALE	WEIGHT	DRAWING TITLE	
	1:2	-- kg		2 STAGE MINI CORDIS-FLG MTG - PRESSURE PUMP-SHORT NOSE-11.9 Lt
	DRAWN- S.HOW	DATE- 23/04/20		
CAD PLOT DO NOT SCALE	CHECKED - S.HOW	DRAWING NUMBER	104-103-00117	
	APPROVED - A.CLIFTON		SHEET 2 OF 2 A3	