

SECTION A-A

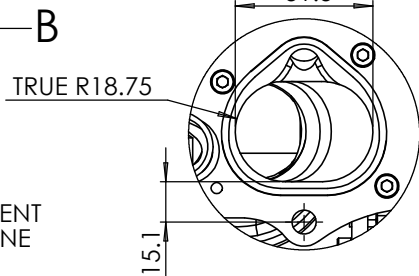
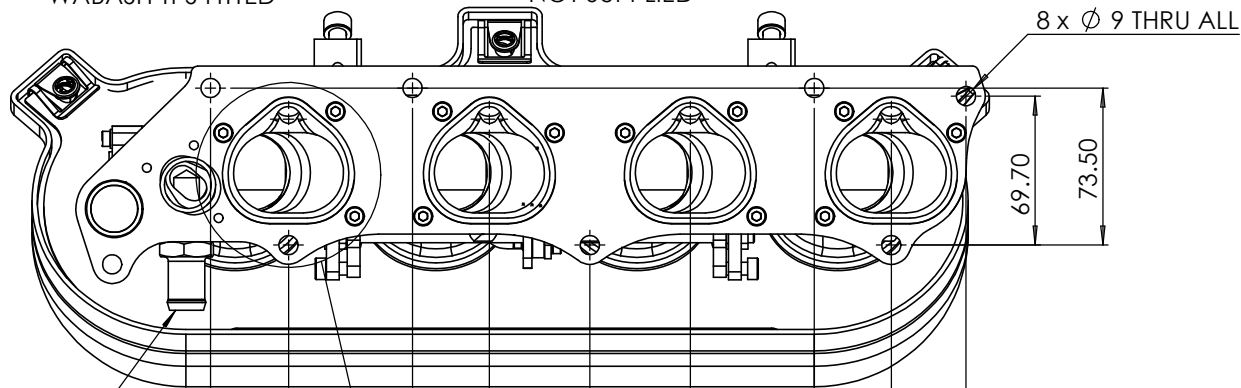

DETAIL B
SCALE 1 : 2

WATER OUTLET
17mm O/D
HOSE FITTING

NOTE:
THIS PRODUCT REQUIRES AN
AFTERMARKET ENGINE MANAGEMENT
SYSTEM (ECU) FOR CORRECT ENGINE
FUELING OPERATION

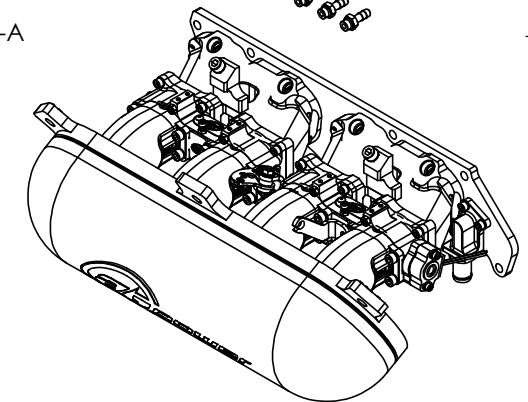

<p>COPYRIGHT (c) 2013 AT POWER LTD UNIT 9, CHESTNUT DRIVE, WYMONDHAM, NORFOLK, UK, NR18 9SB</p> <p>UNLESS OTHERWISE STATED: DIMENSIONS IN MILLIMETRES TOLERANCES: LINEAR ± 0.1 ANGULAR ± 0.5° SURFACE FINISH $\sqrt{\text{V}}$ = $\sqrt{\text{V}}$ DRAWING STANDARDS TO ATQS 6003 DATE FORMAT: DD/MM/YY</p> <p>THIS DESIGN IS THE PROPERTY OF AT POWER THROTTLES LTD AND MUST NOT BE REPRODUCED OR COMMUNICATED WITHOUT AUTHORITY</p>	<p>THIRD ANGLE PROJECTION</p>	MATERIAL	SEE COMPONENT PARTS
	<p>SCALE 1:2.5</p> <p>WEIGHT 5810.133 kg</p>	FINISH	SEE COMPONENT PARTS
<p>DRAWN- S.HOW</p> <p>DATE - 17/05/22</p>	DRAWING TITLE		ASSY-TWIN-HONDA-K20-FD2- STAGGERED-STANDARD INSTALLATION KIT-ITG FILTER
<p>CHECKED - S.HOW</p> <p>APPROVED - A.CLIFFTON</p>	DRAWING NUMBER		102-102-00373
CAD PLOT DO NOT SCALE		SHEET 2 OF 3 A3	