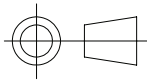

ISOMETRIC VIEW

| | | | | |
|--|---|----------|---|---------------------|
|  COPYRIGHT (c) 2013 AT POWER LTD UNIT 9, CHESTNUT DRIVE, WYMONDHAM, NORFOLK, UK, NR18 9SB |  THIRD ANGLE PROJECTION | MATERIAL | | SEE COMPONENT PARTS |
| | | FINISH | | SEE COMPONENT PARTS |
| UNLESS OTHERWISE STATED: DIMENSIONS IN MILLIMETRES TOLERANCES: LINEAR ± 0.1 ANGULAR ± 0.5° SURFACE FINISH: ✓ = ✓ DRAWING STANDARDS TO ATQS 6003 DATE FORMAT: DD/MM/YY THIS DESIGN IS THE PROPERTY OF AT POWER THROTTLES LTD AND MUST NOT BE REPRODUCED OR COMMUNICATED WITHOUT AUTHORITY | SCALE | WEIGHT | DRAWING TITLE | |
| | 1:1 | 0.1 kg | | |
| | DRAWN- | S.HOW | DRAWING NUMBER | |
| | DATE - | 12/11/19 | 102-105-00002 SHEET 2 OF 2 A3 | |
| CHECKED - | S.HOW | | | |
| APPROVED - | A.CLIFTON | | | |