

NOTES:

1. DISPLACEMENT PER REVERLUTION PER STAGE = 22.0 CC/REV
2. DISPLACEMENT AT 1000 RPM = 22.0 LT/MIN

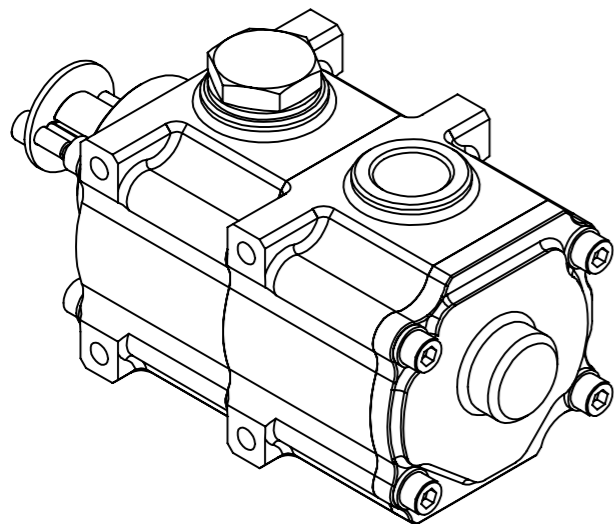
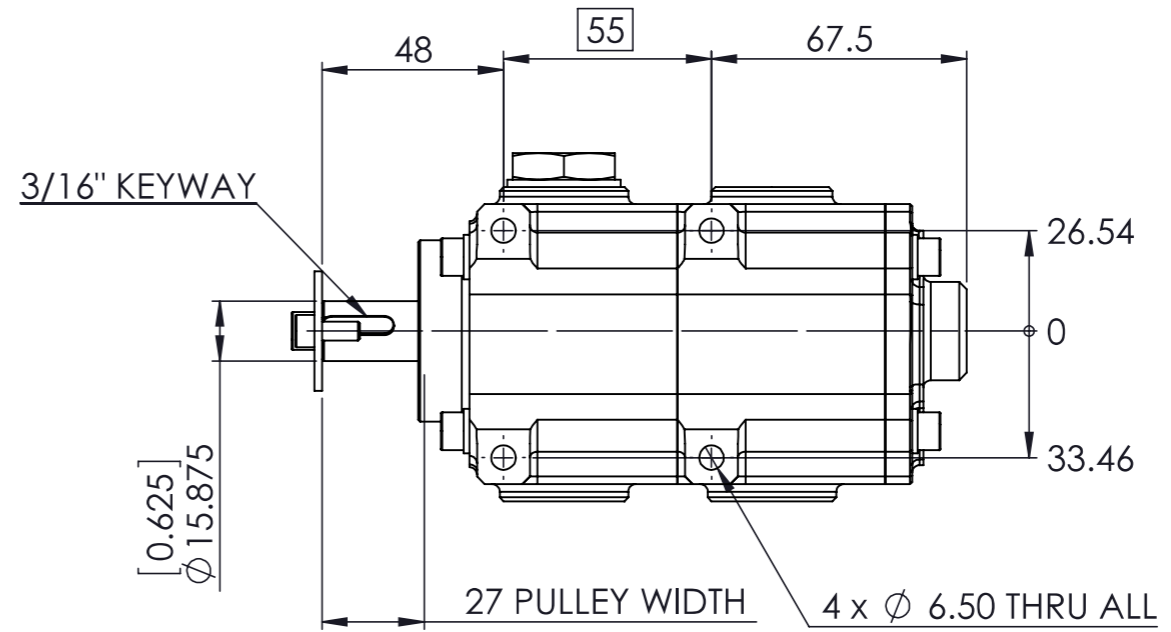
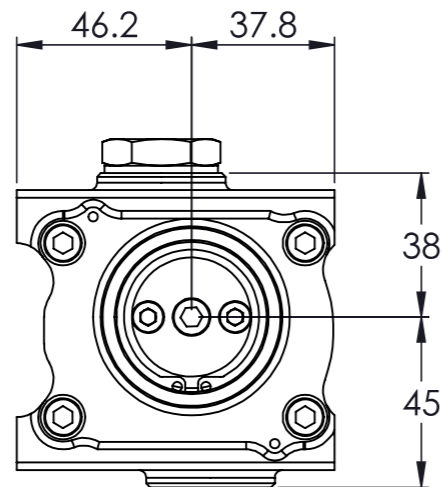
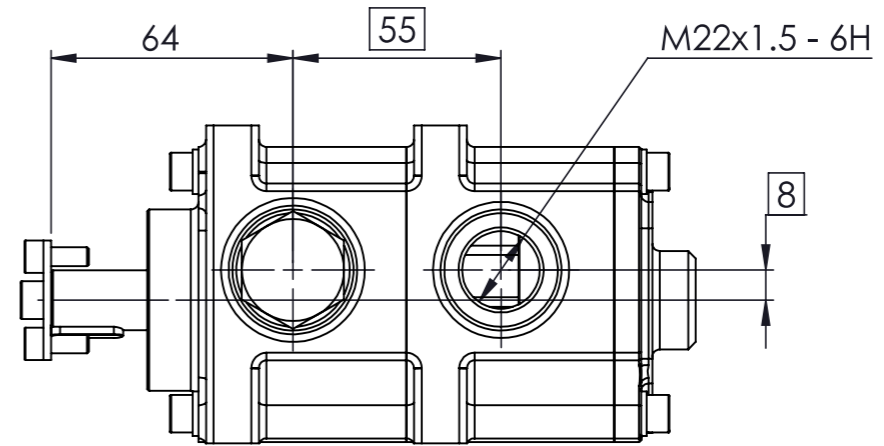

ISOMETRIC VIEW

**COPYRIGHT (c) 2013
AT POWER LTD
UNIT 9, CHESTNUT DRIVE, WYMONDHAM,
NORFOLK, UK, NR18 9SB**

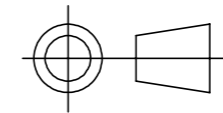

THIRD ANGLE PROJECTION

SCALE 1:2 WEIGHT 2.2 kg

DRAWN- S.HOW

DATE- 12/06/19

CHECKED - S.HOW

APPROVED - A.CLIFTON

UNLESS OTHERWISE STATED:
DIMENSIONS IN MILLIMETRES
TOLERANCES: LINEAR ± 0.1 ANGULAR ± 0.5°
SURFACE FINISH √ = √
DRAWING STANDARDS TO ATQS 6003
DATE FORMAT: DD/MM/YY

THIS DESIGN IS THE PROPERTY OF
ACTIVE TECHNOLOGIES LTD AND
MUST NOT BE REPRODUCED OR
COMMUNICATED WITHOUT
AUTHORITY

CAD PLOT
DO NOT
SCALE

MATERIAL	SEE COMPONENT PART
FINISH	SEE COMPONENT PART
DRAWING TITLE	2 STAGE MAGNA CORDIS-SCAVENGE PUMP-SHORT NOSE-22.0 Ltr
DRAWING NUMBER	104-103-00033