

SECTION F-F

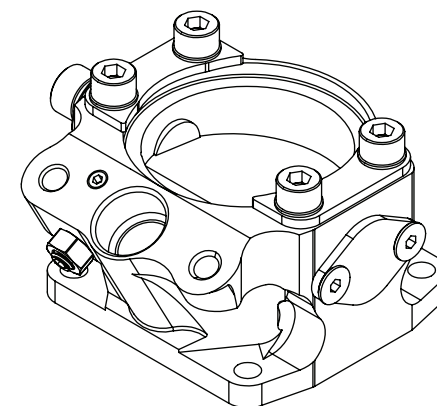
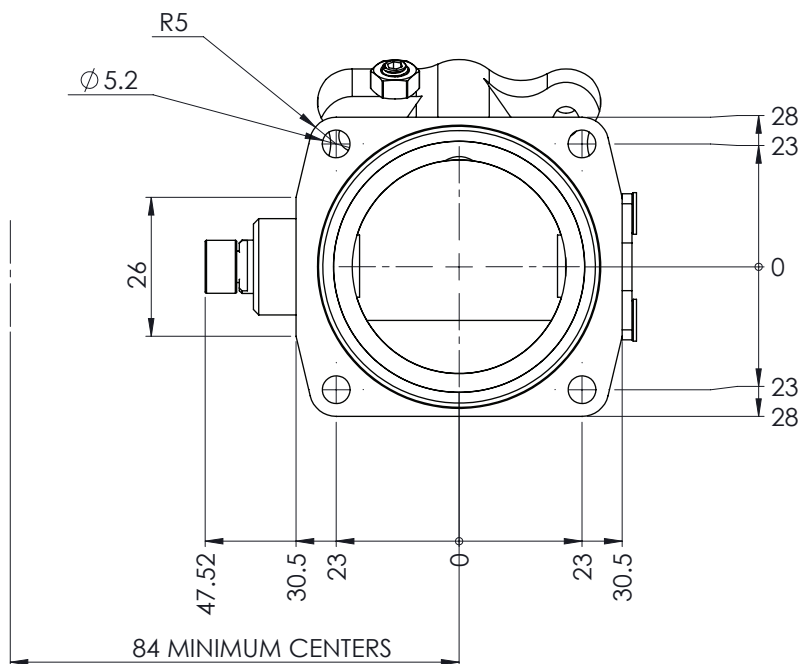

COPYRIGHT (c) 2013
 AT POWER LTD
 UNIT 9, CHESTNUT DRIVE, WYMONDHAM,
 NORFOLK, UK, NR18 9SB

UNLESS OTHERWISE STATED:
 DIMENSIONS IN MILLIMETRES
 TOLERANCES: LINEAR ± 0.1 ANGULAR ± 0.5°
 SURFACE FINISH: ✓ = ✓
 DRAWING STANDARDS TO ATQS 6003
 DATE FORMAT: DD/MM/YY

THIS DESIGN IS THE PROPERTY OF
 AT POWER THROTTLES LTD AND
 MUST NOT BE REPRODUCED OR
 COMMUNICATED WITHOUT
 AUTHORITY

CAD PLOT
 DO NOT
 SCALE

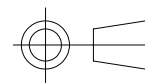

THIRD ANGLE PROJECTION

SCALE
 1:1

WEIGHT
 0.2 kg

DRAWN- S.HOW

DATE - 29/11/19

CHECKED - S.HOW

APPROVED - A.CLIFTON

MATERIAL

SEE COMPONENT PARTS

FINISH

SEE COMPONENT PARTS

DRAWING TITLE

ASSY - HOUSING - SINGLE -
 ROUND - 40MM - INJECTED

DRAWING NUMBER

102-105-00022

SHEET 2 OF 2 A3